



DENGSHANG KITCHEN APPLIANCES

- Kitchen food waste disposer
- Commercial food waste disposer
- Oil-water separator
- Oil press machine
- Food waste composter



Taizhou Dengshang Mechanical&Electrical Co., Ltd.

Jin gang industrial zone, Binhai , Wenling City, Zhejiang,China.

Telephone: 0576-89227356

Fax: 0576-89227377

Official network: www.cndengshang.com

Customer service hotline: 400-0576-588

Alibaba link: <https://dengshang.en.alibaba.com/>

III DENGSHANG PROFILE



Taizhou Dengshang Mechanical & Electrical Co.,Ltd is a high and new-tech enterprise which integrates teams of R&D,manufacture,marketing and service experts. Dengshang has exquisite workmanship,strong product development team,well-know designers focusing on meticulousness and practical applicability. With the concepts of thoroughness,simplicity,science and always improving,Dengshang concentrates on creating humanistic,harmonious,environmentally friendly modern home,providing global users with products advanced in design,leading in technology and reliable in quality.

Dengshang employees are all constantly pursuing”let the job become enjoyment”.With priciple of”professional production,professional quality,professional service ”and pursuing the goal of “professional quality,focused on environment,public media and general consumers for its humanistic products and high quality.

Dengshang is now well know as “Smart Kitchen Cleaning Guard”.Focusing on mastering product details,upgrading technology and providing better service,Dengshang aims to make walks of life at home and abroad to establish partnership with us and create a clean and beautiful world.

III QUALIFIED CERTIFICATES

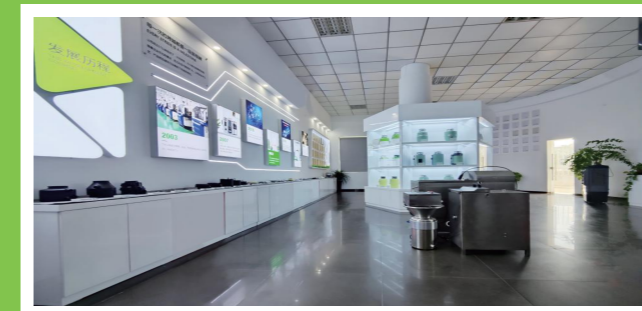

CONTENTS

DST series	01
DSHZ series	06
W/KZ series	08
FZ/WZ series	10
KZ series	16
DSB series	18
M/W series	20
Commercial series	24
Oil-water separator	26
Food waste composter	27
Oil press machine	28

ISO 14001

ISO 9001



CE

CB

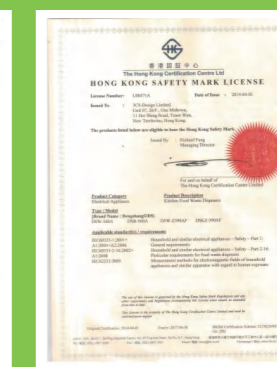
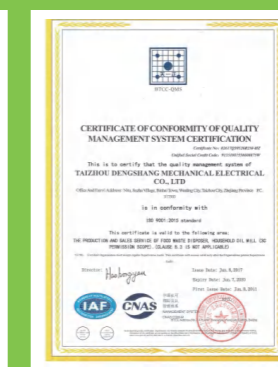

Small but Powerful

Product advantages

- 01 Upgrade ST-motor technology, small size, big wisdom
- 02 Ultra compact design frees up space under the sink



DSTB-560A

Parameters and functions



Grinding Grade	2&3&5
Motor Type	BLDC
Motor HP	3/4HP 560W
Voltage	220-240V/110-120V
Frequency	50Hz/60Hz
No Load RPM	2200r/min
No Load Noise	≈30-40dB
Grinding Capacity	1100ml
Overload Protector	Yes
Starting Method	Remote Control
NW/GW	5/8kg
Size of Product	230*200*240mm
Warranty	3 Years

DST-560A

Parameters and functions



Grinding Grade	2&3&5
Motor Type	BLDC
Motor HP	3/4HP 560W
Voltage	220-240V/110-120V
Frequency	50Hz/60Hz
No Load RPM	2200r/min
No Load Noise	≈30-40dB
Grinding Capacity	1100ml
Overload Protector	Yes
Starting Method	Remote Control
NW/GW	5/8kg
Size of Product	180*160*210mm
Warranty	3 Years

DSTC-560A

Parameters and functions



Grinding Grade	2&3
Motor Type	BLDC
Motor HP	3/4HP 560W
Voltage	220-240V/110-120V
Frequency	50Hz/60Hz
No Load RPM	2200r/min
No Load Noise	≈30-40dB
Grinding Capacity	1500ml+Filter basket
Overload Protector	Yes
Starting Method	Remote Control
NW/GW	7/10kg
Size of Product	230*200*240mm
Warranty	3 Years

DSTA-560A

Parameters and functions



Grinding Grade	2&3&5
Motor Type	BLDC
Motor HP	3/4HP 560W
Voltage	220-240V/110-120V
Frequency	50Hz/60Hz
No Load RPM	2200r/min
No Load Noise	≈30-40dB
Grinding Capacity	1100ml
Overload Protector	Yes
Starting Method	Remote Control
NW/GW	5/8kg
Size of Product	225*190*230mm
Warranty	3 Years

DSTD-560A

Parameters and functions



Grinding Grade	2&3
Motor Type	BLDC
Motor HP	3/4HP 560W
Voltage	220-240V/110-120V
Frequency	50Hz/60Hz
No Load RPM	2200r/min
No Load Noise	≈30-40dB
Grinding Capacity	1500ml+Filter basket
Overload Protector	Yes
Starting Method	Remote Control
NW/GW	7/10kg
Size of Product	230*200*230mm
Warranty	3 Years

Dengshang®

PROFESSIONAL FOOD WASTE DISPOSER FACTORY



DSTE-560A

Parameters and functions



Grinding Grade	2&3&5
Motor Type	BLDC
Motor HP	3/4HP 560W
Voltage	220-240V/110-120V
Frequency	50Hz/60Hz
No Load RPM	2200r/min
No Load Noise	≈30-40dB
Grinding Capacity	1100ml
Overload Protector	Yes
Starting Method	Remote Control
NW/GW	5/8kg
Size of Product	190*170*230mm
Warranty	3 Years



DSTG-560A

Parameters and functions



Grinding Grade	2&3
Motor Type	BLDC
Motor HP	3/4HP 560W
Voltage	220-240V/110-120V
Frequency	50Hz/60Hz
No Load RPM	2200r/min
No Load Noise	≈30-40dB
Grinding Capacity	1500ml+Filter basket
Overload Protector	Yes
Starting Method	Remote Control
NW/GW	7/10kg
Size of Product	190*170*230mm
Warranty	3 Years





DSHZ SERIES

DSHZ-560A

Parameters and functions



Grinding Grade	2&3
Motor Type	BLDC
Motor HP	3/4HP 560W
Voltage	220-240V/110-120V
Frequency	50Hz/60Hz
No Load RPM	2200r/min
No Load Noise	≈30-40dB
Grinding Capacity	1500ml+Filter basket
Overload Protector	Yes
Starting Method	Air Switch
NW/GW	8.2/9.5kg
Size of Product	260*230*330mm
Warranty	3 Years



DSHZB-560A

Parameters and functions



Grinding Grade	2&3
Motor Type	BLDC
Motor HP	3/4HP 560W
Voltage	220-240V/110-120V
Frequency	50Hz/60Hz
No Load RPM	2200r/min
No Load Noise	≈30-40dB
Grinding Capacity	1500ml+Filter basket
Overload Protector	Yes
Starting Method	Air Switch
NW/GW	8.2/9.5kg
Size of Product	260*220*320mm
Warranty	3 Years



DSHZG-560A

Parameters and functions



Grinding Grade	2&3
Motor Type	BLDC
Motor HP	3/4HP 560W
Voltage	220-240V/110-120V
Frequency	50Hz/60Hz
No Load RPM	2200r/min
No Load Noise	≈30-40dB
Grinding Capacity	1500ml+Filter basket
Overload Protector	Yes
Starting Method	Air Switch
NW/GW	8.2/9.5kg
Size of Product	260*220*320mm
Warranty	3 Years





DSWA-560A

Parameters and functions



Grinding Grade	2&3
Motor Type	AC
Motor HP	3/4HP 560W
Voltage	220-240V/110-120V
Frequency	50Hz/60Hz
No Load RPM	1480r/min
No Load Noise	≈40-50dB
Grinding Capacity	1500ml+Filter basket
Overload Protector	Yes
Starting Method	Air Switch
NW/GW	12/13kg
Size of Product	260*230*330mm
Warranty	3 Years

DSKZG-560A

Parameters and functions



Grinding Grade	2&3&5
Motor Type	DC
Motor HP	3/4HP 560W
Voltage	220-240V/110-120V
Frequency	50Hz/60Hz
No Load RPM	3000r/min
No Load Noise	≈50-60dB
Grinding Capacity	1500ml
Overload Protector	Yes
Starting Method	Air Switch
NW/GW	6.5/7.5kg
Size of Product	240*230*370mm
Warranty	2 Years

DSWC-560A

Parameters and functions



Grinding Grade	2&3
Motor Type	AC
Motor HP	3/4HP 560W
Voltage	220-240V/110-120V
Frequency	50Hz/60Hz
No Load RPM	1480r/min
No Load Noise	≈40-50dB
Grinding Capacity	1500ml+Filter basket
Overload Protector	Yes
Starting Method	Air Switch
NW/GW	12/13kg
Size of Product	260*220*330mm
Warranty	3 Years

DSKZM-560A

Parameters and functions



Grinding Grade	2&3&5
Motor Type	DC
Motor HP	3/4HP 560W
Voltage	220-240V/110-120V
Frequency	50Hz/60Hz
No Load RPM	3000r/min
No Load Noise	≈50-60dB
Grinding Capacity	1500ml
Overload Protector	Yes
Starting Method	Air Switch
NW/GW	6.5/7.5kg
Size of Product	240*230*370mm
Warranty	2 Years

DSFZ-390A
Parameters and functions

Grinding Grade	4
Motor Type	DC
Motor HP	1/2HP 390W
Voltage	220-240V/110-120V
Frequency	50Hz/60Hz
No Load RPM	3200r/min
No Load Noise	≈60-70dB
Grinding Capacity	900ml
Overload Protector	Overload, Over temperature
Starting Method	Air Switch
NW/GW	4.2/4.7kg
Size of Product	140*120*390mm
Warranty	1 Year

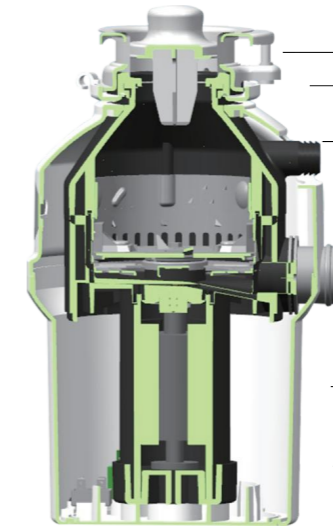

- Feeding mouth(sink connector)
- Installation part
- Double hollow structure(shock absorption and sound insulation)
- Dishwasher connector
- Composite nylon fiberglass grinding chamber
- Ever-lasting lubricated oil bearing sewage pipe connector
- High pulling torque DC motor
- Overload, overcurrent protection equipment

DSWZ-390A
Parameters and functions

Grinding Grade	2&3&5
Motor Type	DC
Motor HP	1/2HP 390W
Voltage	220-240V/110-120V
Frequency	50Hz/60Hz
No Load RPM	3000r/min
No Load Noise	≈50-60dB
Grinding Capacity	1100ml
Overload Protector	Overload, Over temperature
Starting Method	Air Switch
NW/GW	6/6.5kg
Size of Product	180*160*330mm
Warranty	2 Years

DSWZB-390A
Parameters and functions

Grinding Grade	2&3&5
Motor Type	DC
Motor HP	1/2HP 390W
Voltage	220-240V/110-120V
Frequency	50Hz/60Hz
No Load RPM	3000r/min
No Load Noise	≈50-60dB
Grinding Capacity	1100ml
Overload Protector	Overload, Over temperature
Starting Method	Air Switch
NW/GW	6/6.5kg
Size of Product	230*210*330mm
Warranty	2 Years

DSWZC-390A
Parameters and functions

Grinding Grade	2&3&5
Motor Type	DC
Motor HP	1/2HP 390W
Voltage	220-240V/110-120V
Frequency	50Hz/60Hz
No Load RPM	3000r/min
No Load Noise	≈50-60dB
Grinding Capacity	1100ml
Overload Protector	Overload, Over temperature
Starting Method	Air Switch
NW/GW	6/6.5kg
Size of Product	230*220*330mm
Warranty	2 Years

DSWZD-390A
Parameters and functions

Grinding Grade	2&3&5
Motor Type	DC
Motor HP	1/2HP 390W
Voltage	220-240V/110-120V
Frequency	50Hz/60Hz
No Load RPM	3000r/min
No Load Noise	≈50-60dB
Grinding Capacity	1100ml
Overload Protector	Overload, Over temperature
Starting Method	Air Switch
NW/GW	6/6.5kg
Size of Product	210*170*330mm
Warranty	2 Years



DSKZ-560A

Parameters and functions



Grinding Grade	2&3&5
Motor Type	DC
Motor HP	3/4HP 560W
Voltage	220-240V/110-120V
Frequency	50Hz/60Hz
No Load RPM	3000r/min
No Load Noise	≈50-60dB
Grinding Capacity	1500ml
Overload Protector	Overload, Over temperature
Starting Method	Air Switch
NW/GW	6.4/7kg
Size of Product	230*210*370mm
Warranty	2 Years



DSKZT-560A

Parameters and functions



Grinding Grade	2&3&5
Motor Type	DC
Motor HP	3/4HP 560W
Voltage	220-240V/110-120V
Frequency	50Hz/60Hz
No Load RPM	3000r/min
No Load Noise	≈50-60dB
Grinding Capacity	1500ml
Overload Protector	Overload, Over temperature
Starting Method	Air Switch
NW/GW	6.4/7kg
Size of Product	230*200*370mm
Warranty	2 Years



DSKZU-560A

Parameters and functions



Grinding Grade	2&3&5
Motor Type	DC
Motor HP	3/4HP 560W
Voltage	220-240V/110-120V
Frequency	50Hz/60Hz
No Load RPM	3000r/min
No Load Noise	≈50-60dB
Grinding Capacity	1500ml
Overload Protector	Overload, Over temperature
Starting Method	Air Switch
NW/GW	6.4/7kg
Size of Product	230*200*370mm
Warranty	2 Years



DSKZV-560A

Parameters and functions



Grinding Grade	2&3&5
Motor Type	DC
Motor HP	3/4HP 560W
Voltage	220-240V/110-120V
Frequency	50Hz/60Hz
No Load RPM	3000r/min
No Load Noise	≈50-60dB
Grinding Capacity	1500ml
Overload Protector	Overload, Over temperature
Starting Method	Air Switch
NW/GW	6.4/7kg
Size of Product	230*200*370mm
Warranty	2 Years





CLEAN CITY

For our next generation, handle the food waste in house

Recently, the environmental problems have aroused the public concern, and the kitchen food waste takes a large proportion.

Effectively deal with our kitchen waste, better life creat for our cute children.

DSKZD-560A

Parameters and functions

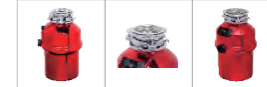

Grinding Grade	2&3&5
Motor Type	DC
Motor HP	3/4HP 560W
Voltage	220-240V/110-120V
Frequency	50Hz/60Hz
No Load RPM	3000r/min
No Load Noise	≈50-60dB
Grinding Capacity	1500ml
Overload Protector	Overload、Over temperature
Starting Method	Air Switch
NW/GW	6.4/7kg
Size of Product	230*210*370mm
Warranty	2 Years



DSKZL-560A

Parameters and functions



Grinding Grade	2&3&5
Motor Type	DC
Motor HP	3/4HP 560W
Voltage	220-240V/110-120V
Frequency	50Hz/60Hz
No Load RPM	3000r/min
No Load Noise	≈50-60dB
Grinding Capacity	1500ml
Overload Protector	Overload、Over temperature
Starting Method	Air Switch
NW/GW	6.4/7kg
Size of Product	220*200*370mm
Warranty	2 Years



DSKZS-560A

Parameters and functions



Grinding Grade	2&3&5
Motor Type	DC
Motor HP	3/4HP 560W
Voltage	220-240V/110-120V
Frequency	50Hz/60Hz
No Load RPM	3000r/min
No Load Noise	≈50-60dB
Grinding Capacity	1500ml
Overload Protector	Overload、Over temperature
Starting Method	Air Switch
NW/GW	6.4/7kg
Size of Product	220*200*370mm
Warranty	2 Years



Quick grinding



DSKZR-560A

Parameters and functions



Grinding Grade	2&3&5
Motor Type	DC
Motor HP	3/4HP 560W
Voltage	220-240V/110-120V
Frequency	50Hz/60Hz
No Load RPM	3000r/min
No Load Noise	≈50-60dB
Grinding Capacity	1500ml
Overload Protector	Overload、Over temperature
Starting Method	Remote Control
NW/GW	6.4/7kg
Size of Product	220*200*370mm
Warranty	2 Years



DSKZI-560A

Parameters and functions



Grinding Grade	2&3&5
Motor Type	DC
Motor HP	3/4HP 560W
Voltage	220-240V/110-120V
Frequency	50Hz/60Hz
No Load RPM	3000r/min
No Load Noise	≈50-60dB
Grinding Capacity	1500ml
Overload Protector	Overload、Over temperature
Starting Method	Remote Control
NW/GW	6.4/7kg
Size of Product	220*200*370mm
Warranty	2 Years



DSKZC-560A

Parameters and functions



Grinding Grade	2&3&5
Motor Type	DC
Motor HP	3/4HP 560W
Voltage	220-240V/110-120V
Frequency	50Hz/60Hz
No Load RPM	3000r/min
No Load Noise	≈50-60dB
Grinding Capacity	1500ml
Overload Protector	Overload、Over temperature
Starting Method	Remote Control
NW/GW	6.4/7kg
Size of Product	220*200*370mm
Warranty	2 Years



DSKZX-560A

Parameters and functions



Grinding Grade	2&3&5
Motor Type	DC
Motor HP	3/4HP 560W
Voltage	220-240V/110-120V
Frequency	50Hz/60Hz
No Load RPM	3000r/min
No Load Noise	≈50-60dB
Grinding Capacity	1500ml
Overload Protector	Overload、Over temperature
Starting Method	Remote Control
NW/GW	7.5/8.5kg
Size of Product	210*190*370mm
Warranty	2 Years



QUICK GRINDING

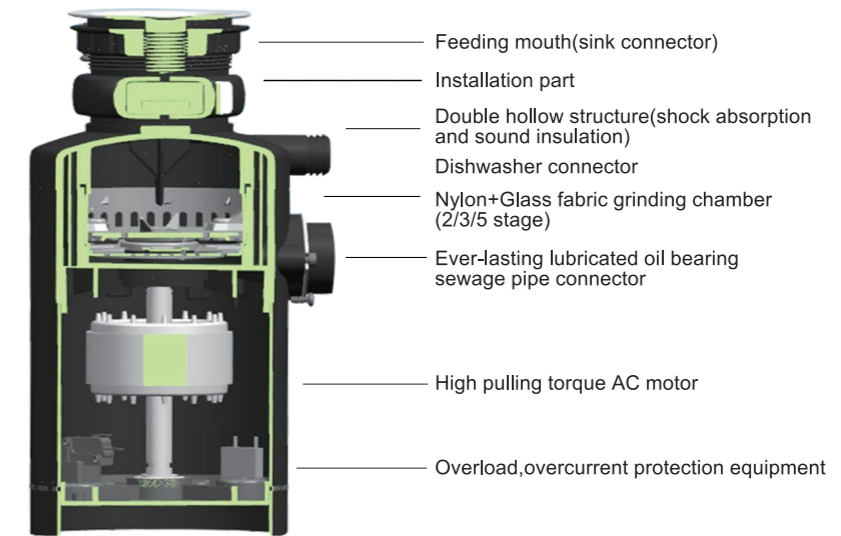

DSBA-560A

Parameters and functions



Grinding Grade	2&3&5
Motor Type	AC
Motor HP	3/4HP 560W
Voltage	220-240V/110-120V
Frequency	50Hz/60Hz
No Load RPM	1480r/min
No Load Noise	≈40-50dB
Grinding Capacity	1100ml
Overload Protector	Overload、Over temperature
Starting Method	Air Switch
NW/GW	6.5/7.5kg
Size of Product	230*210*300mm
Warranty	3 Years



DSB-560A

Parameters and functions



Grinding Grade	2&3&5
Motor Type	AC
Motor HP	3/4HP 560W
Voltage	220-240V/110-120V
Frequency	50Hz/60Hz
No Load RPM	1480r/min
No Load Noise	≈40-50dB
Grinding Capacity	1100ml
Overload Protector	Overload、Over temperature
Starting Method	Air Switch
NW/GW	6.2/7.2kg
Size of Product	180*160*300mm
Warranty	3 Years



DSB-390A

Parameters and functions



Grinding Grade	2&3&5
Motor Type	AC
Motor HP	1/2HP 390W
Voltage	220-240V/110-120V
Frequency	50Hz/60Hz
No Load RPM	1480r/min
No Load Noise	≈40-50dB
Grinding Capacity	1100ml
Overload Protector	Overload、Over temperature
Starting Method	Air Switch
NW/GW	6/7kg
Size of Product	180*160*300mm
Warranty	3 Years



DSB-750A

Parameters and functions



Grinding Grade	2&3
Motor Type	AC
Motor HP	1HP 750W
Voltage	220-240V/110-120V
Frequency	50Hz/60Hz
No Load RPM	1480r/min
No Load Noise	≈40-50dB
Grinding Capacity	1600ml
Overload Protector	Yes
Starting Method	Air Switch
NW/GW	8.5/9.5kg
Size of Product	210*180*340mm
Warranty	3 Years

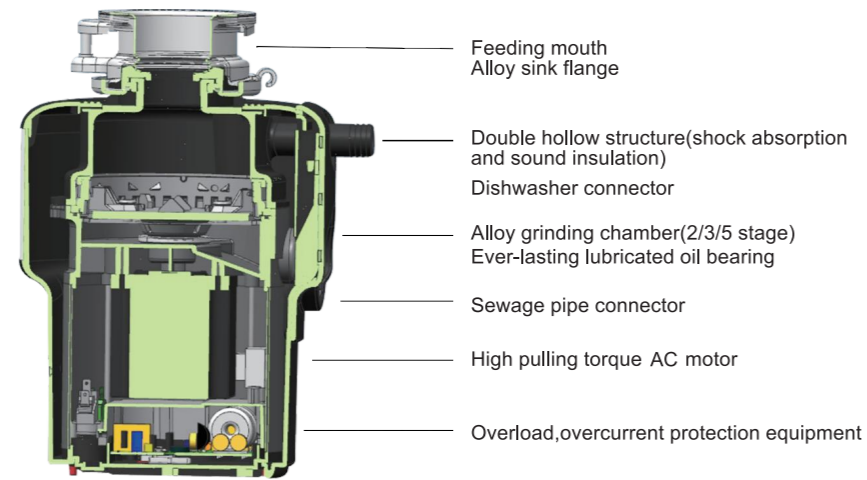

- Feeding mouth
Alloy sink flange
- Double hollow structure(shock absorption and sound insulation)
- Dishwasher connector
- Alloy grinding chamber(2/3/5 stage)
Ever-lasting lubricated oil bearing
- Sewage pipe connector
- High pulling torque AC motor
- Overload,overcurrent protection equipment

DSM-560A
Parameters and functions

Grinding Grade	2&3
Motor Type	AC
Motor HP	3/4HP 560W
Voltage	220-240V/110-120V
Frequency	50Hz/60Hz
No Load RPM	1480r/min
No Load Noise	≈40-50dB
Grinding Capacity	1500ml+Filter basket
Overload Protector	Yes
Starting Method	Air Switch
NW/GW	10.8/11.7kg
Size of Product	250*210*320mm
Warranty	3 Years

DSME-560A
Parameters and functions

Grinding Grade	2&3
Motor Type	AC
Motor HP	3/4HP 560W
Voltage	220-240V/110-120V
Frequency	50Hz/60Hz
No Load RPM	1480r/min
No Load Noise	≈40-50dB
Grinding Capacity	1500ml+Filter basket
Overload Protector	Yes
Starting Method	Air Switch
NW/GW	11.9/13.2kg
Size of Product	260*220*330mm
Warranty	3 Years

DSW-560A
Parameters and functions

Grinding Grade	2&3
Motor Type	AC
Motor HP	3/4HP 560W
Voltage	220-240V/110-120V
Frequency	50Hz/60Hz
No Load RPM	1480r/min
No Load Noise	≈40-50dB
Grinding Capacity	1500ml+Filter basket
Overload Protector	Yes
Starting Method	Air Switch
NW/GW	11.7/13kg
Size of Product	260*230*330mm
Warranty	3 Years

DSWB-560A
Parameters and functions

Grinding Grade	2&3
Motor Type	AC
Motor HP	3/4HP 560W
Voltage	220-240V/110-120V
Frequency	50Hz/60Hz
No Load RPM	1480r/min
No Load Noise	≈40-50dB
Grinding Capacity	1500ml+Filter basket
Overload Protector	Yes
Starting Method	Air Switch
NW/GW	11.9/13.2kg
Size of Product	230*220*320mm
Warranty	3 Years

DSWF-560A
Parameters and functions

Grinding Grade	2&3
Motor Type	AC
Motor HP	3/4HP 560W
Voltage	220-240V/110-120V
Frequency	50Hz/60Hz
No Load RPM	1480r/min
No Load Noise	≈40-50dB
Grinding Capacity	1500ml+Filter basket
Overload Protector	Yes
Starting Method	Air Switch
NW/GW	11/12.2kg
Size of Product	260*220*330mm
Warranty	3 Years





DS-SY1500E

Parameters and functions



Grinding Grade	3
Motor Type	AC
Motor HP	2HP
Voltage	220-240V/110-120V
Frequency	50Hz/60Hz
No Load RPM	1480r/min
No Load Noise	≈40-50dB
Grinding Capacity	2400ml
Overload Protector	Yes
Starting Method	Touching Switch
NW/GW	60/70kg
Size of Product	54*48*82cm
Warranty	1 Year



DS-SY1500G

Parameters and functions



Grinding Grade	3
Motor Type	AC
Motor HP	2HP
Voltage	220-240V/110-120V
Frequency	50Hz/60Hz
No Load RPM	1480r/min
No Load Noise	≈40-50dB
Grinding Capacity	2400ml
Overload Protector	Yes
Starting Method	Touching Switch
NW/GW	60/70kg
Size of Product	56*40*82cm
Warranty	1 Year



DS-SY2200G

Parameters and functions



Grinding Grade	3
Motor Type	AC
Motor HP	3HP
Voltage	220-240V/110-120V
Frequency	50Hz/60Hz
No Load RPM	1600r/min
No Load Noise	≈40-50dB
Grinding Capacity	2400ml
Overload Protector	Yes
Starting Method	Touching Switch
NW/GW	150/160kg
Size of Product	97*60*90cm
Warranty	1 Year



SAVING POWER

Auto water inflowing system

Large power
Lower noise

High-end stainless steel, durable advantages

AC motor

Touching switch button
Commercial food waste disposer



COMMERCIAL SERIES

DS-SY1500

Parameters and functions



Grinding Grade	3
Motor Type	AC
Motor HP	2HP
Voltage	220-240V/110-120V
Frequency	50Hz/60Hz
No Load RPM	1480r/min
No Load Noise	≈40-50dB
Grinding Capacity	2400ml
Overload Protector	Yes
Starting Method	Touching Switch
NW/GW	38/45kg
Size of Product	40*40*50cm
Warranty	1 Year



DS-SY1500H

Parameters and functions



Grinding Grade	3
Motor Type	AC
Motor HP	2HP
Voltage	220-240V/110-120V
Frequency	50Hz/60Hz
No Load RPM	1480r/min
No Load Noise	≈40-50dB
Grinding Capacity	2400ml+Funnel volume:10L
Overload Protector	Yes
Starting Method	Touching Switch
NW/GW	40/50kg
Size of Product	40*40*65cm
Warranty	1 Year



DS-SY1500F

Parameters and functions



Grinding Grade	3
Motor Type	AC
Motor HP	2HP
Voltage	220-240V/110-120V
Frequency	50Hz/60Hz
No Load RPM	1480r/min
No Load Noise	≈40-50dB
Grinding Capacity	2400ml
Overload Protector	Yes
Starting Method	Touching Switch
NW/GW	70/80kg
Size of Product	80*48*85cm
Warranty	1 Year



AUTOMATIC SEPARATION OF OIL, WATER AND SLUDGE



**SMART KITCHEN
WASTE PROCESSOR
(IOT VERSION)**

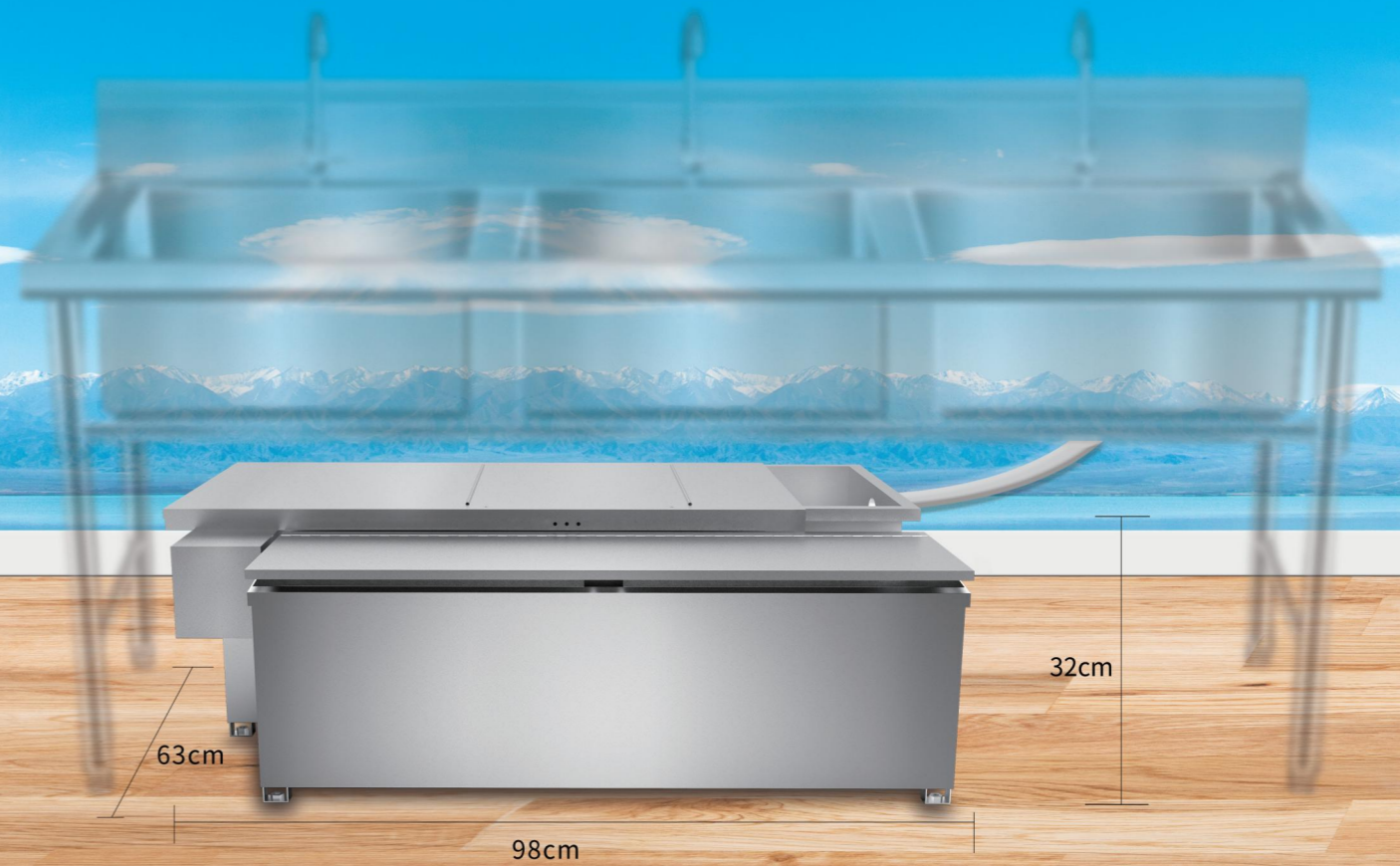

DS-H150A

Parameters and functions



Motor Type	AC
Motor HP	2HP(AC300W,heating module 1200w)
Voltage	220-240V/110-120V
Frequency	50Hz/60Hz
No Load RPM	15r/min
No Load Noise	≈40-50dB
Grinding Capacity	40L
Overload Protector	Yes
Starting Method	Touching Switch
NW/GW	105/130kg
Size of Product	115*65*98cm(Includes slag bucket)
Warranty	1 Year

DS-H120A

Parameters and functions



Motor Type	AC
Motor HP	AC40W,heating module 1200w
Voltage	220-240V/110-120V
Frequency	50Hz/60Hz
No Load Noise	≈40-50dB
Grinding Capacity	28L
Overload Protector	Yes
Starting Method	Timed power on switch
NW/GW	45/50kg
Size of Product	98*61*32cm
Warranty	1 Year

DFA-25A
Parameters and functions

Motor Type	DC
Motor HP	Heating 500W+Motor 50W
Voltage	220-240V/110-120V
Frequency	50Hz/60Hz
Motor Speed	8r/min
Noise Level	30-40dB
Capacity	2.5L
Processing Speed	4.5 hours
Auto-reverse	Yes
Self-cleaning	Yes
Size of Product	295*240*304mm
NW/GW	5.2/6.2 KG

DFB-40A
Parameters and functions

Motor Type	DC
Motor HP	Heating 500W+Motor 50W
Voltage	220-240V/110-120V
Frequency	50Hz/60Hz
Motor Speed	8r/min
Noise Level	30-40dB
Capacity	4L
Processing Speed	Standard 4-6 hours, fast 2.5-5 hours
Auto-reverse	Yes
Self-cleaning	Yes
Size of Product	325*264*342mm
NW/GW	7.1/8.3 KG

DSZYJ-750A
Parameters and functions

Color	silver
Size	480*180*210mm
Weight	12.5KG
Shell	304 stainless steel
Press chamber/pole	304 stainless steel
Press size (diameter*length)	25mm*200mm
Capacity	10kg/h
Oil yield rate	45%
Type	cold-press
Automatic Grade	Automatic
LCD	No
Noise level	40-50db
Pre-heat time	5 minutes
Rated Voltage	220-240V
Motor Rating	AC400W
Heating rating	400W
Motor speed	80r/min
Frequency	50HZ
Warranty	1 year
Life time	10 years

DFC-30A
Parameters and functions

Motor Type	DC
Motor HP	Heating 500W+Motor 50W
Voltage	220-240V/110-120V
Frequency	50Hz/60Hz
Motor Speed	8r/min
Noise Level	30-40dB
Capacity	3L
Processing Speed	Standard 4-6 hours, fast 2.5-5 hours
Auto-reverse	Yes
Self-cleaning	Yes
Size of Product	350*260*320mm
NW/GW	5.5/6.5 KG

DFD-45A
Parameters and functions

Motor Type	DC
Motor HP	Heating 500W+Motor 50W
Voltage	220-240V/110-120V
Frequency	50Hz/60Hz
Motor Speed	8r/min
Noise Level	30-40dB
Capacity	4.5L
Processing Speed	Standard 4-6 hours, fast 2.5-5 hours
Auto-reverse	Yes
Self-cleaning	Yes
Size of Product	320*260*320mm
NW/GW	7.5/8.5 KG

DSZYJ-200A
Parameters and functions

Color	white/green/red
Size	415*183*280mm
Weight	4KG
Shell	ABS
Press chamber/pole	304 stainless steel
Press size (diameter*length)	20mm*180mm
Capacity	2-3 kg/h
Oil yield rate	45%
Type	hot+cold-press
Automatic Grade	Automatic
LCD	Yes
Noise level	20-30db
Pre-heat time	5 minutes
Rated Voltage	220-240V
Motor Rating	DC90W
Heating rating	120W
Motor speed	50 r/min
Frequency	50HZ
Warranty	1 year
Life time	10 years